

TECHNICAL CARD



Ceiling spotlight luminaire



Pursuant to the provisions of the WEEE Act, it is forbidden to put waste equipment marked with the symbol of a crossed out bin together with other waste. The user, wishing to get rid of electronic and electrical equipment, is obliged to return it to a waste equipment collection point. There are no hazardous components in the equipment that have a particularly negative impact on the environment and human health.

VIDEX®



IK07



-25° +50°C



Free



IP20

WARRANTY 2 YEARS

General parameters

Light source replaceable end user

Electrical parameters

Rated voltage, frequency AC 220-240 V, 50/60 Hz

Input interface Terminal block

Electric shock protection class I

Additional information

Place of installation Ceiling

Place of application indoor

Impact protection IK07

Housing colour Black

Operating temperature range -25° +50°C

Mercury content Does not contain

Ingress protection IP20

Housing material Aluminum

Dimensions

EAN 4820246484701

Height 82 mm

VIDEX for GX53 lamp VL-SPF18B-B

INDEX: VL-SPF18B-B

Depth 80 mm

Width 80 mm

In the package 1 pc.

Outer box 50 pcs.

Unit nett weight 300g

Signs marking goods

Packaging marking CE, Utilization



INDEX: VL-SPF18B-B

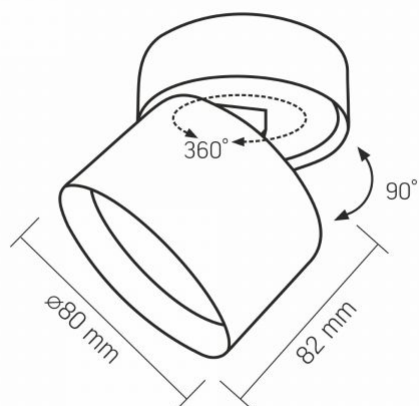
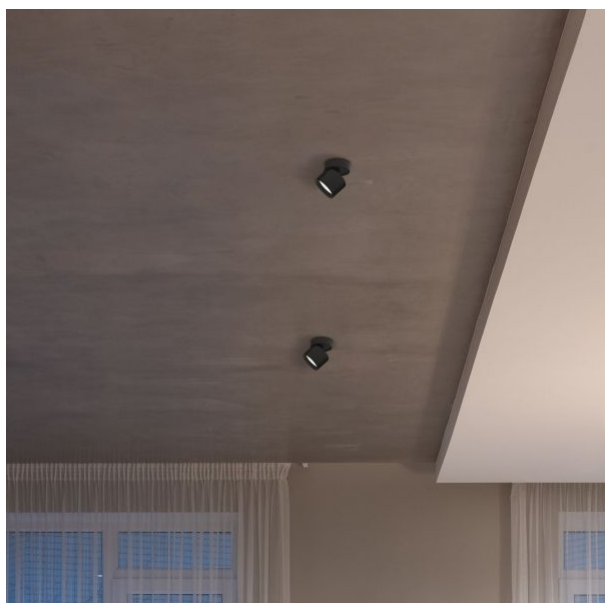

We reserve the right to make technical changes. The data contained in this material is not legally binding.

Allegro opt Sp. z o.o., ul. Mierzeja Wiślana 11,
30-732 Krakow, Poland.



The product must be used indoors



Protection against electric shock class I. A product in which the means of protection against electric shock, in addition to the main insulation, is an additional protective circuit connected to the grounding of the power supply network



The product meets the requirements of EU directives



It is forbidden to throw away waste equipment marked with the symbol of a crossed-out bin with other waste



The product withstands a medium impact (e.g., from a blunt object)



Operating temperatures range



The product does not contain mercury



Class of protection against dust and moisture. Protection against solid objects larger than 12 mm; no protection against moisture